



FigNoggle Designs

CNC Plans for Asian Mini-Mills

Asian/SIEMENS-made (X2) mini-mills
Harbor Freight (#44991), Grizzly (#G8689), Micro-Mark (#62573), Homier (#3347), Cummins (#7877)

FEEL FREE TO DISTRIBUTE.

NOTES:

1. THIS IS THE DRO DISPLAY HOLDER ASSEMBLY.
2. ROD SLIDES AND ROTATES FOR AXIAL AND RADIAL ADJUSTMENTS.
3. BRACKET ROTATES FOR EASIER VIEWING OF DISPLAY.
4. AMBIDEXTROUS ASSEMBLY.

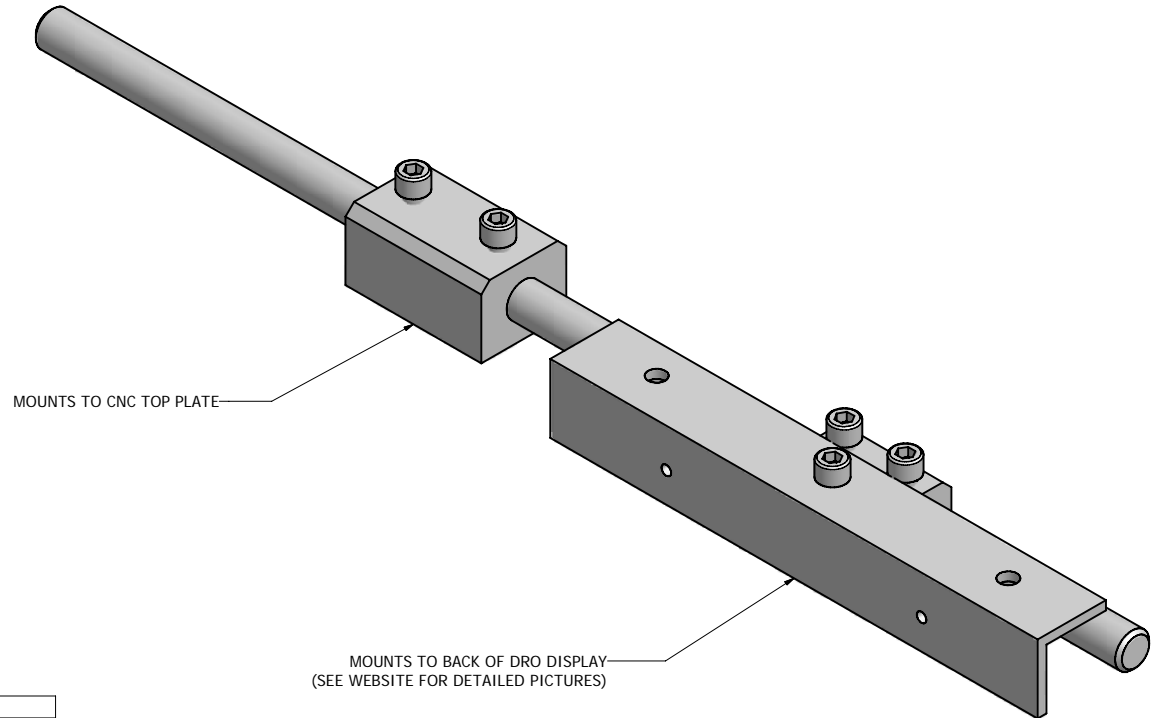

Parts List			
ITEM	QTY	PART NUMBER	DESCRIPTION
1	1	DRODisplayBlock	
2	1	DRODisplayRod	
3	1	DRODisplayBracketBlock	
4	1	DRODisplayBracket	1" ANGLE ALUMINUM
5	5	1/4 - 20 - 3/8	Hexagon Socket Head Cap Screw

Copyright 2006. david@fignoggle.com figNoggle Designs. All rights reserved.

CNC CONVERSION PLANS FOR YOUR SIEG X2 MINI-MILL.
DRO PLANS AND MORE AT WWW.FIGNOGGLE.COM.

DRAWN david@fignoggle.com	4/1/2006	figNoggle Designs / www.fignoggle.com	
CHECKED		TITLE	
QA		DRO Display Holder Assembly	
MFG		SIZE C	DWG NO figNoggle_DRODisplayHolderAssembly
APPROVED		SCALE	REV
			SHEET 1 OF 1



FigNoggle Designs

CNC Plans for Asian Mini-Mills

Harbor Freight (#44991), Grizzly (#08689), Micro-Mark (#62573), Homier (#3947), Cummins (#7877)
Asian/SIEMENS-made (X2) mini-mills

FEEL FREE TO DISTRIBUTE.

NOTES:

1. THIS IS THE DRO DISPLAY MOUNT BRACKET.
2. LINEAR TOLERANCES +/- 0.005".
3. SUGGESTED MATERIAL: 6061 1" ANGLE ALUMINUM.
4. DIMENSIONS ARE IN INCHES.

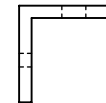
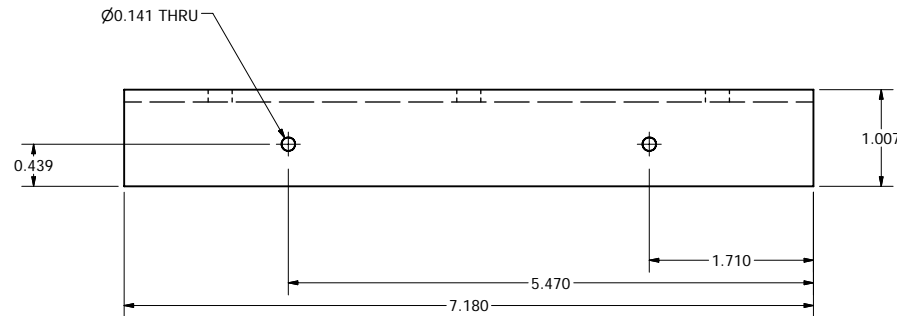
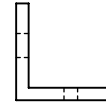
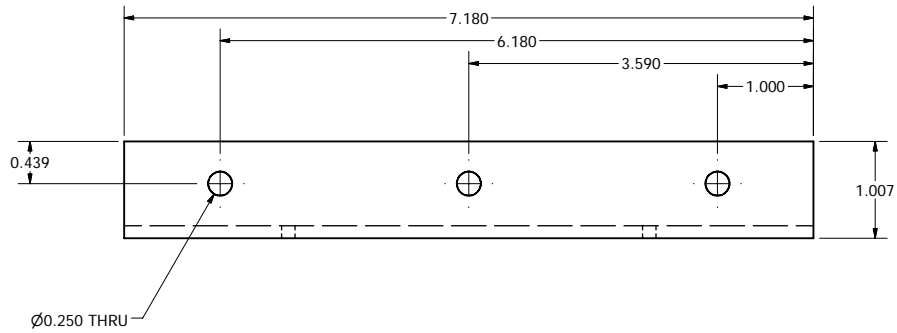
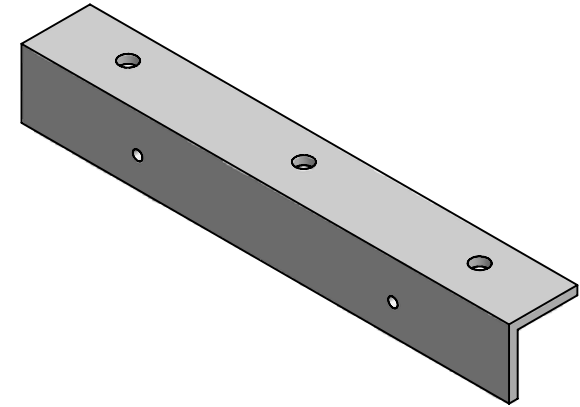

Copyright 2006. david@fignoggle.com figNoggle Designs. All rights reserved.

DRAWN david@fignoggle.com	3/9/2006	figNoggle Designs / www.fignoggle.com		
CHECKED		TITLE		
QA		DRO Display Bracket		
MFG		SIZE	DWG NO	REV
APPROVED		C	DRODisplayBracket	1
		SCALE	SHEET 1 OF 1	

CNC CONVERSION PLANS FOR YOUR SIEG X2 MINI-MILL.
DRO PLANS AND MORE AT WWW.FIGNOGGLE.COM.



FigNoggle Designs

CNC Plans for Asian Mini-Mills

Harbor Freight (#44992), Grizzly (#G8689), Micro-Mark (#62573), Homier (#3947), Cummins (#7077)
Asian/SINO-made (X2) mini-mills

FEEL FREE TO DISTRIBUTE.

NOTES:

1. THIS IS THE BASE MOUNTING BLOCK FOR THE DRO DISPLAY HOLDER ASSEMBLY.
2. LINEAR TOLERANCES +/- 0.005".
3. SUGGESTED MATERIAL: 6061 ALUMINUM.
4. DIMENSIONS ARE IN INCHES.

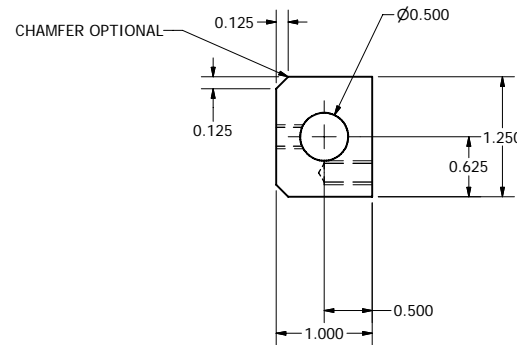
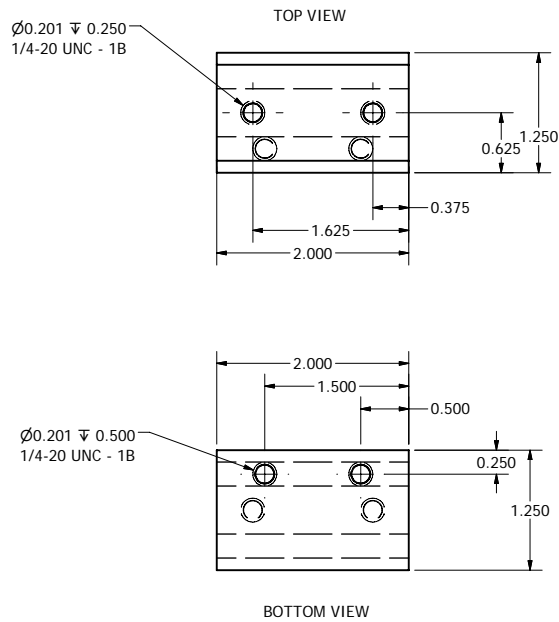
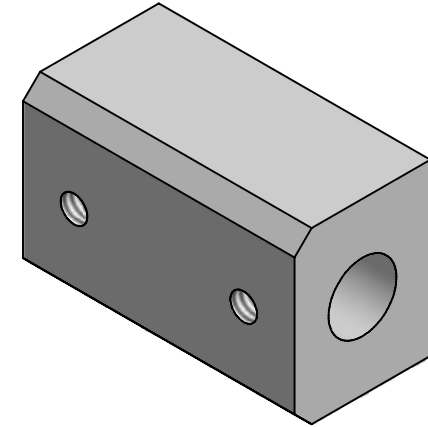

Copyright 2006. david@fignoggle.com figNoggle Designs. All rights reserved.

CNC CONVERSION PLANS FOR YOUR SIEG X2 MINI-MILL.
DRO PLANS AND MORE AT WWW.FIGNOGGLE.COM.

DRAWN david@fignoggle.com	3/9/2006	figNoggle Designs / www.fignoggle.com		
CHECKED		TITLE		
QA		DRO Display Base Mounting Block		
MFG				
APPROVED				
		SIZE C	DWG NO DRODisplayBase	REV 1
		SCALE	SHEET 1 OF 1	



FigNoggle Designs

CNC Plans for Asian Mini-Mills

Asian/SIEG-made (X2) mini-mills
Harbor Freight (#44993), Grizzly (#08689), Micro-Mark (#02573), Homier (#3947), Cummins (#7877)

FEEL FREE TO DISTRIBUTE.

NOTES:

1. THIS IS THE DISPLAY BRACKET MOUNTING BLOCK.
2. LINEAR TOLERANCES +/- 0.005".
3. SUGGESTED MATERIAL: 6061 ALUMINUM.
4. DIMENSIONS ARE IN INCHES.

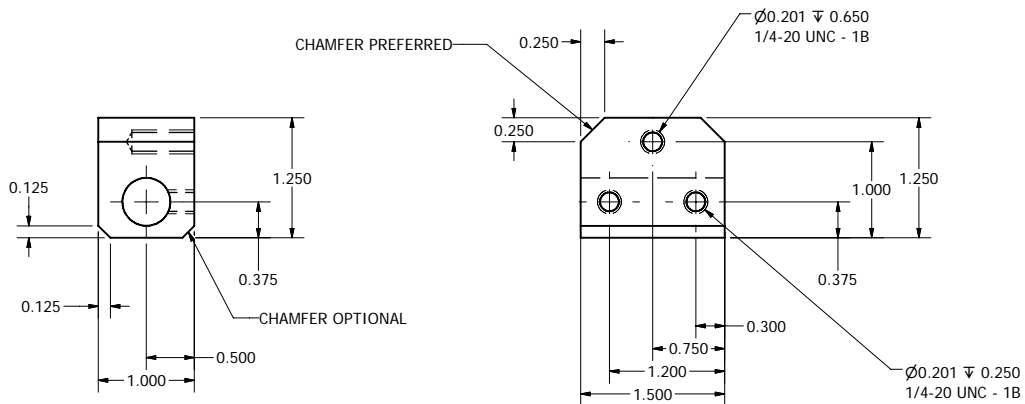
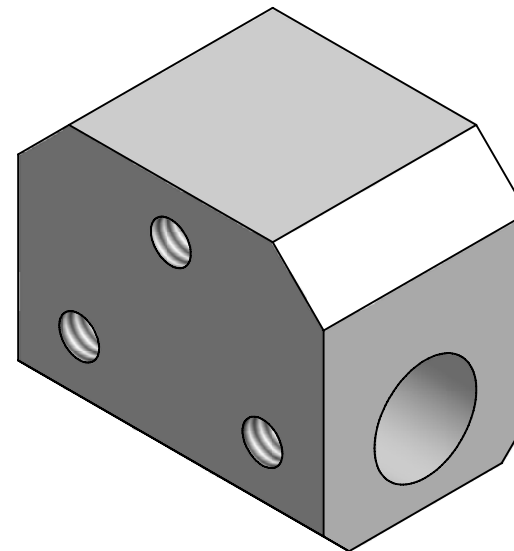

Copyright 2006. david@fignoggle.com figNoggle Designs. All rights reserved.

CNC CONVERSION PLANS FOR YOUR SIEG X2 MINI-MILL.
DRO PLANS AND MORE AT WWW.FIGNOGGLE.COM.

DRAWN	david@fignoggle.com	3/9/2006	figNoggle Designs / www.fignoggle.com	
CHECKED			TITLE	
QA			DRO Display Bracket Mounting Block	
MFG			SIZE	DWG NO
APPROVED			C	DRODisplayBracketBlock
			SCALE	REV
				1
			SHEET 1 OF 1	



FigNoggle Designs

CNC Plans for Asian Mini-Mills

Asian/SINO-made (X2) mini-mills
Harbor Freight (#44591), Grizzly (#08689), Micro-Mark (#82573), Homier (#3947), Cummins (#7877)

FEEL FREE TO DISTRIBUTE.

NOTES:

1. THIS IS THE SLIDE ROD.
2. SUGGESTED MATERIAL: MILD STEEL ROD.
3. DIMENSIONS ARE IN INCHES.

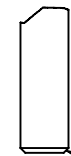
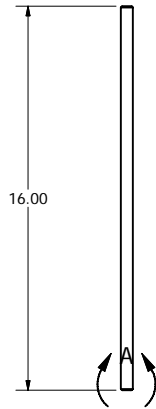
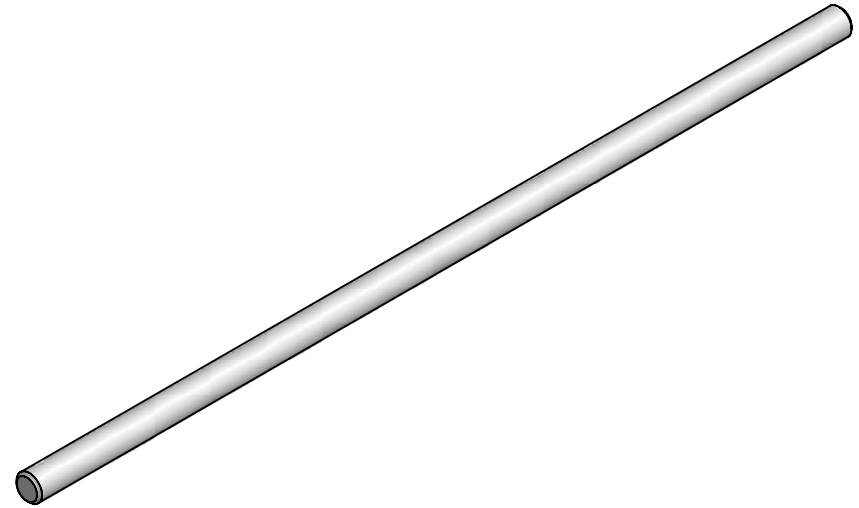

DETAIL A
LIGHT CHAMFER OR SOFTEN EDGE WITH FILE

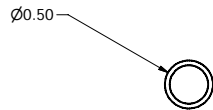

Copyright 2006. david@fignoggle.com figNoggle Designs. All rights reserved.

CNC CONVERSION PLANS FOR YOUR SIEG X2 MINI-MILL.
DRO PLANS AND MORE AT **WWW.FIGNOGGLE.COM**.

DRAWN	david@fignoggle.com	3/9/2006	figNoggle Designs / www.fignoggle.com	
CHECKED			TITLE	
QA			DRO Display Rod	
MFG			SIZE	DWG NO
APPROVED			C	DRODisplayRod
			SCALE	REV
				1
			SHEET 1 OF 1	